

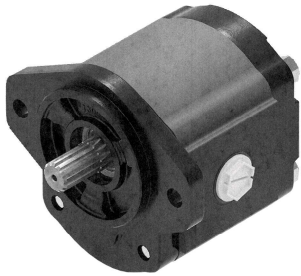

P U M P S

Gear Pumps



FEATURES:

- Reversible gear sets
- Cast iron front & back covers
- Viton seals available
- Working pressures up to 3600 PSI
- Customization available
 - Flanges
 - Shaft sizes
 - Flow control rear cover
- Double pumps: Available in WPA, WPB & WPC
- Maximum speed from 2500 to 4000 RPM using SAE 10W oil
- Displacement covers 0.27 in³/rev. to 4.48 in³/rev.
- Inlet pressure: Pump inlet should not exceed 5 in. of mercury vacuum or 14 PSI positive pressure
- Ports: SAE straight thread O-ring boss for WPA, WPB & WPC
- Working oil: A mineral based oil with additives to resist corrosion oxidation, & foaming is recommended. Viscosity at any running condition should be 60 SUS minimum & 250 SUS maximum. 180° F is the maximum recommended system operating temperature
- Filtration: Per ISO cleanliness code level 17/14/15 micron filtration for full PSI is recommended

WP Gear Pumps

MODEL NUMBER	DISPLACEMENT CU IN/REV	RATED PRESSURE (PSI)	SHAFT TYPE	WT LBS.	LIST PRICE
WPA06A2R	.4	3600	5/8 KEYED	7.7	337.00
† WPA06A3R	.4	3600	SAE 11T SPLINE	7.7	Call
WPA06A9R	.4	3600	SAE 9T SPLINE	7.7	337.00
WPA08A2L	.5	3600	5/8 KEYED	7.9	342.00
WPA08A2R	.5	3600	5/8 KEYED	7.9	342.00
WPA08A4R	.5	3600	3/4 KEYED	7.9	342.00
WPA08A9L	.5	3600	SAE 9T SPLINE	7.9	342.00
WPA08A9R	.5	3600	SAE 9T SPLINE	7.9	342.00
† WPA10A2L	.65	3600	5/8 KEYED	8.2	Call
WPA10A2R	.65	3600	5/8 KEYED	8.2	349.00
WPA10A4R	.65	3600	3/4 KEYED	8.2	349.00
WPA11A2R	.68	3600	5/8 KEYED	8.3	351.00
WPA11A9L	.68	3600	SAE 9T SPLINE	8.3	351.00
† WPA11A9L-P150	.68	3600	SAE 9T SPLINE	8.5	Call
WPA11A9R	.68	3600	SAE 9T SPLINE	8.3	351.00
WPA14A2R	.84	3600	5/8 KEYED	8.5	353.00
† WPA14A4L	.84	3600	3/4 KEYED	8.5	Call
WPA14A4R	.84	3600	3/4 KEYED	8.5	Call
WPA14A9R	.84	3600	SAE 9T SPLINE	8.5	353.00
† WPA14D9R	.84	3600	SAE 9T SPLINE	8.5	Call
WPA16A2L	1.01	3500	5/8 KEYED	8.8	366.00
WPA16A2R	1.01	3500	5/8 KEYED	8.8	366.00
WPA16A4R	1.01	3500	3/4 KEYED	8.8	366.00
WPA16A9L	1.01	3600	SAE 9T SPLINE	8.8	366.00
WPA16A9R	1.01	3500	SAE 9T SPLINE	8.8	366.00
† WPA19A2L	1.18	3600	5/8 KEYED	9.2	Call
WPA19A2R	1.18	3000	5/8 KEYED	9.2	376.00
† WPA19A4L	1.18	3000	3/4 KEYED	9.2	Call
WPA19A9L	1.18	3000	SAE 9T SPLINE	9.2	376.00
WPA19A9R	1.18	3000	SAE 9T SPLINE	9.2	376.00
WPA23A2R	1.37	2750	5/8 KEYED	9.5	383.00
WPA23A9L	1.37	2900	SAE 9T SPLINE	9.5	383.00
WPA23A9R	1.37	2750	SAE 9T SPLINE	9.5	383.00
WPA26A2R	1.58	2500	5/8 KEYED	10.1	388.00
† WPA26A9R	1.58	2500	SAE 9T SPLINE	10.1	Call

† NON-STOCKED ITEMS AVAILABLE AT STANDARD LEAD-TIME.

CHECK OUR PRINCE WEBSITE OR CONTACT YOUR SALES REP TO VERIFY IF NON-STOCKED ITEMS ARE STILL ON HAND FOR IMMEDIATE SHIPMENT.



P U M P S

WP Gear Pumps (continued)

MODEL NUMBER	DISPLACEMENT CU IN/REV	RATED PRESSURE (PSI)	SHAFT TYPE	WT LBS.	LIST PRICE
† WPB19A5R	1.16	3600	SAE 13T SPLINE	7.9	Call
WPB22A6R	1.35	3600	7/8 KEYED	8.3	544.00
WPB28A6R	1.68	3600	7/8 KEYED	9.9	557.00
† WPB32A6R	1.97	3300	7/8 KEYED	10.5	567.00
† WPB38A5L	2.32	2900	SAE 13T SPLINE	11	Call
† WPB38A5R	2.32	2900	SAE 13T SPLINE	11	Call
WPB38A6R	2.32	2900	7/8 KEYED	11	589.00
WPB44A5R	2.69	2500	SAE 13T SPLINE	11.7	596.00
WPB44A6R	2.69	2500	7/8 KEYED	11.7	728.00
WPC21A5R-RD	1.26	3600	SAE 13T SPLINE	13	998.00
† WPC27A6R-RD	1.65	3600	7/8 KEYED	13.5	Call
WPC55A5R-RD	3.30	3200	SAE 13T SPLINE	15	957.00
WPC55A6R	3.30	3200	7/8 KEYED	15	1,014.00
† WPC55A6R-RD	3.30	3200	7/8 KEYED	15	Call
WPC65A5L	3.85	2900	SAE 13T SPLINE	15.5	1,072.00
† WPC65A5L-RD	3.85	2900	SAE 13T SPLINE	15.5	Call
WPC65A6L	3.85	2900	7/8 KEYED	15.5	879.00
† WPC65A6R	3.85	2900	7/8 KEYED	15.5	879.00
† WPC65A6R-RD	3.85	2900	7/8 KEYED	15.5	Call
† WPHL0616A2R	0.4 / 1.41	3600 / 600	5/8 KEYED	14	Call
† WPHL0823A2R	0.5 / 1.87	3600 / 600	5/8 KEYED	15	Call

SEAL KIT	LIST PRICE
PMCK-WPA	66.00
PMCK-WPB	66.00
PMCK-WPC	73.00

† NON-STOCKED ITEMS AVAILABLE AT STANDARD LEAD-TIME.

CHECK OUR PRINCE WEBSITE OR CONTACT YOUR SALES REP TO VERIFY IF NON-STOCKED ITEMS ARE STILL ON HAND FOR IMMEDIATE SHIPMENT.



P U M P S

WPA A Flange Gear Pumps Specifications & Dimensional Data

WPA 08 A 4 R

DISPLACEMENT CODE	CC / REV	CU. IN. / REV	CONTINUOUS PSI	RATED SPEED (RPM)	INLET PORT SIZE	OUTLET PORT SIZE	"A"	"B"
04	4.6	0.27	3600	4000	#12 SAE	#10 SAE	3.50	1.68
06	6.5	0.40	3600	4000	#12 SAE	#10 SAE	3.60	1.73
08	8.2	0.50	3600	3500	#12 SAE	#10 SAE	3.62	1.79
10	10.6	0.65	3600	3500	#12 SAE	#10 SAE	3.73	1.86
11	11.5	0.68	3600	3500	#12 SAE	#10 SAE	3.87	1.92
12	12.5	0.77	3600	3500	#12 SAE	#10 SAE	3.93	1.95
14	13.8	0.84	3600	3500	#12 SAE	#10 SAE	4.00	2.00
16	16.6	1.01	3600	3000	#12 SAE	#10 SAE	4.15	2.08
19	19.4	1.18	3200	3000	#12 SAE	#10 SAE	4.31	2.24
23	22.9	1.37	2900	2750	#12 SAE	#10 SAE	4.63	2.34
26	25.8	1.58	2600	2500	#12 SAE	#10 SAE	4.84	2.46

ROTATION (FACING END OF SHAFT)	
L	COUNTER CLOCKWISE
R	CLOCKWISE

SHAFT CODE	SHAFT TYPE
9	9 T SAE SPLINE
2	SAE 5/8" STRAIGHT KEYED
3	11 T SAE SPLINE
4	3/4" STRAIGHT KEYED

PORT LOCATION CODE	PORT LOCATION
A	SIDE INLET AND OUTLET
C*	BOTH SIDE AND REAR PORTS W/ STEEL PLUGS
D*	REAR INLET AND OUTLET

* ADD 0.35" FOR LENGTH "A" FOR REAR PORTS

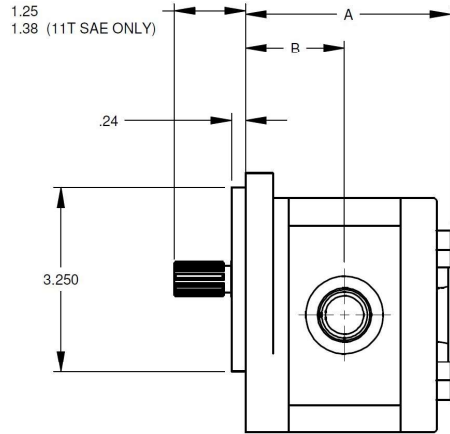
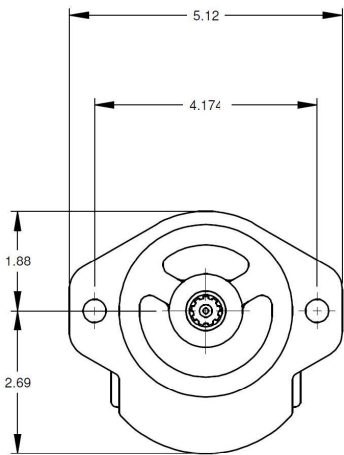

SHAFT OPTIONS

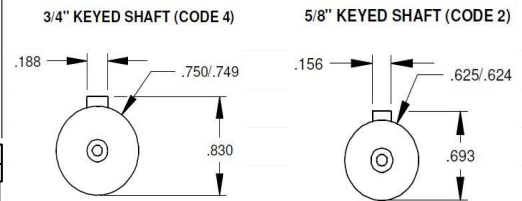

SPLINED SHAFT OPTIONS

- | | |
|---|--|
| SHAFT CODE 9
9 TOOTH SAE
16/32 DP
30° PA | SHAFT CODE 3
11 T SAE
16/32 DP
30° PA |
|---|--|

WPA Performance Data

MODEL		RPM								PRESSURE (PSI)
		500	1000	1500	2000	2500	3000	3500	4000	
WPA06	FLOW (GPM)	0.73	1.54	2.37	3.16	3.99	4.84	5.65	6.45	3600
	INPUT HP	2.07	4.13	6.20	8.26	10.33	12.39	14.46	16.52	
WPA08	FLOW (GPM)	0.92	1.95	2.99	3.98	5.03	6.10	7.12		
	INPUT HP	2.61	5.21	7.82	10.42	13.03	15.63	18.24		
WPA10	FLOW (GPM)	1.19	2.52	3.86	5.15	6.51	7.89	9.21		
	INPUT HP	3.37	6.74	10.11	13.47	16.84	20.21	23.58		
WPA11	FLOW (GPM)	1.32	2.79	4.28	5.71	7.22	8.76	10.21		
	INPUT HP	3.74	7.47	11.21	14.95	18.69	22.42	26.16		
WPA14	FLOW (GPM)	1.55	3.28	5.03	6.70	8.47	10.27	11.99		
	INPUT HP	4.39	8.77	13.16	17.54	21.93	26.31	30.70		
WPA16	FLOW (GPM)	1.86	3.94	6.05	8.06	10.19	12.36			
	INPUT HP	5.28	10.55	15.83	21.10	26.38	31.65			
WPA19	FLOW (GPM)	2.18	4.61	7.07	9.42	11.91	14.44			
	INPUT HP	5.43	10.85	16.28	21.70	27.13	32.55			
WPA23	FLOW (GPM)	2.57	5.44	8.34	11.12	14.06				
	INPUT HP	5.82	11.64	17.46	23.29	29.11				
WPA26	FLOW (GPM)	2.89	6.13	9.40	12.53	15.84				
	INPUT HP	5.90	11.81	17.71	23.61	29.51				



P U M P S

WPB B Flange Gear Pumps Specifications & Dimensional Data

WPB 38 A 5 R

DISPLACEMENT CODE	CU. IN. / REV	CONTINUOUS PSI	RATED SPEED (RPM)	INLET PORT SIZE	OUTLET PORT SIZE	"A"	"B"
16	0.97	3600	3000	SAE #12	SAE #10	4.45	2.05
19	1.16	3600	3000	SAE #12	SAE #10	4.53	2.13
22	1.35	3600	3000	SAE #12	SAE #10	4.66	2.2
25	1.53	3600	3000	SAE #16	SAE #12	4.95	2.35
28	1.68	3600	3000	SAE #16	SAE #12	5.25	2.5
32	1.97	3300	3000	SAE #16	SAE #12	5.47	2.61
38	2.32	2900	2750	SAE #16	SAE #12	5.77	2.72
44	2.69	2450	2500	SAE #16	SAE #12	6.02	2.9

ROTATION (FACING END OF SHAFT)	
L	(COUNTER CLOCKWISE)
R	(CLOCKWISE)

SHAFT CODE	SHAFT TYPE
5	SAE 13 TOOTH SPLINE
6	SAE 7/8" KEYED STRAIGHT

PORT LOCATION CODE	PORT LOCATION
A	SIDE INLET AND OUTLET
C	BOTH SIDE AND REAR PORTS W/ STEEL PLUGS
D	REAR INLET AND OUTLET

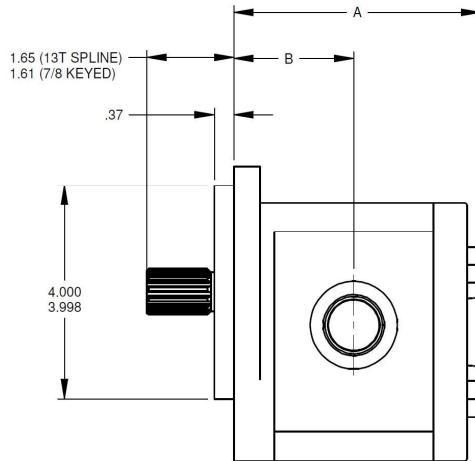
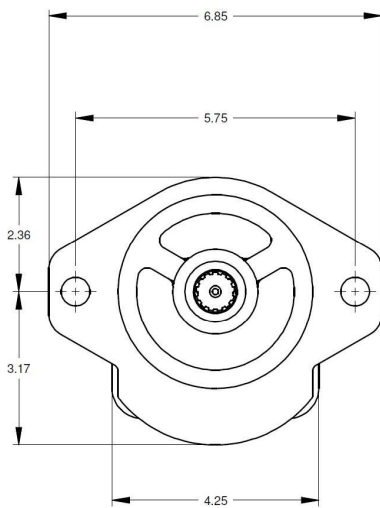

SHAFT OPTIONS

SHAFT CODE 5

SAE 13T SPLINE
16/32 DP
30° PA

SHAFT CODE 6
7/8" STRAIGHT KEYED

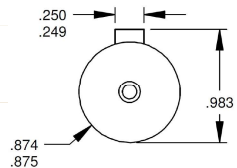

WPB Performance Data

MODEL		RPM						PRESSURE
		500	1000	1500	2000	2500	3000	(PSI)
WPB19	FLOW (GPM)	2.17	4.59	7.03	9.38	11.85	14.37	3600
	INPUT HP	6.13	12.27	18.40	24.53	30.67	36.80	
WPB22	FLOW (GPM)	2.49	5.27	8.09	10.78	13.63	16.53	
	INPUT HP	7.05	14.11	21.16	28.22	35.27	42.33	
WPB28	FLOW (GPM)	3.10	6.56	10.06	13.41	16.94	20.55	
	INPUT HP	8.77	17.54	26.31	35.08	43.85	52.62	
WPB32	FLOW (GPM)	3.64	7.70	11.80	15.74	19.89	24.12	
	INPUT HP	9.47	18.94	28.42	37.89	47.36	56.83	
WPB38	FLOW (GPM)	4.27	9.05	13.88	18.51	23.39		3000
	INPUT HP	9.69	19.37	29.06	38.74	48.43		
WPB44	FLOW (GPM)	4.96	10.50	16.10	21.47	27.13		2500
	INPUT HP	9.55	19.10	28.65	38.20	47.76		



P U M P S

WPC B Flange Gear Pumps Specifications & Dimensional Data

WPC 44 A 5 R

DISPLACEMENT CODE	CU. IN. / REV	CONTINUOUS PSI	RATED SPEED (RPM)	INLET PORT SIZE	OUTLET PORT SIZE	"A"	"B"
21	1.26	3600	3000	SAE #16	SAE #12	5.06	2.33
27	1.65	3600	3000	SAE #16	SAE #12	5.26	2.43
33	2.04	3600	3000	SAE #16	SAE #12	5.46	2.52
38	2.36	3600	2750	SAE #16	SAE #12	5.61	2.60
46	2.86	3600	2750	SAE #20	SAE #16	6.24	2.92
55	3.3	3200	2500	SAE #20	SAE #16	6.43	3.04
65	3.85	2900	2500	SAE #20	SAE #16	6.75	3.17
75	4.48	2600	2500	SAE #20	SAE #16	7.03	3.31

ROTATION (FACING END OF SHAFT)	
L	(COUNTER CLOCKWISE)
R	(CLOCKWISE)

SHAFT CODE	SHAFT TYPE
5	SAE 13 TOOTH SPLINE
6	SAE 7/8" KEYED STRAIGHT
7	SAE 15 TOOTH SPLINE

PORT LOCATION CODE	PORT LOCATION
A	SIDE INLET AND OUTLET
C	BOTH SIDE AND REAR PORTS W/ STEEL PLUGS*

* ADD 0.14" TO LENGTH "A" FOR REAR PORTS

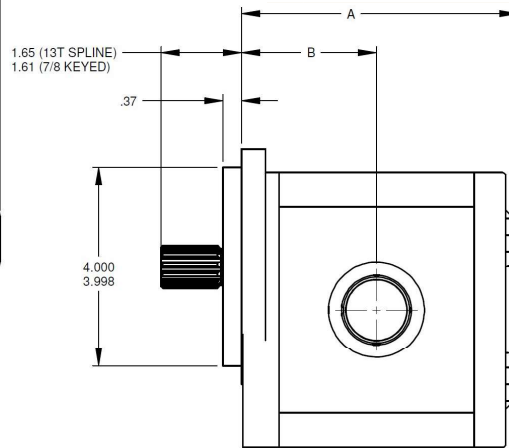
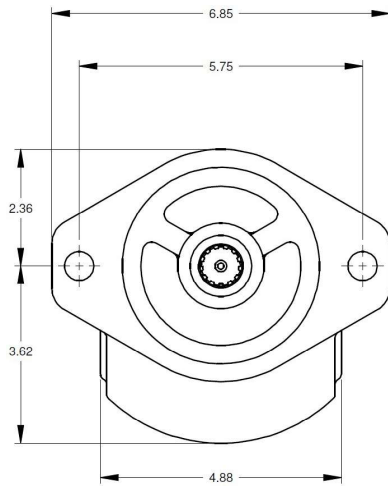

SHAFT OPTIONS

SHAFT CODE 5
SAE 13T SPLINE
16/32 DP
30° PA
FLAT ROOT SIDE FIT

SHAFT CODE 6
7/8" STRAIGHT KEYED

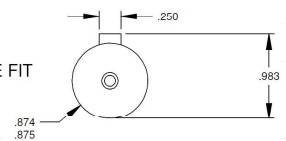

WPC Performance Data

MODEL		RPM					PRESSURE (PSI)
		500	1000	1500	2000	2500	
WPC55	FLOW (GPM)	6.07	12.85	19.71	26.28	33.21	3300
	INPUT HP	15.13	30.26	45.39	60.51	75.64	
WPC65	FLOW (GPM)	7.08	14.99	22.99	30.65	38.73	3000
	INPUT HP	16.04	32.08	48.12	64.17	80.21	